

NOTES:

1. There is no regulator on this design. Regulated +5V is expected to be supplied to the board through J3.
2. If RTS/CTS flow-control handshaking is not to be used, jumper RTS\_232 to CTS\_232.
3. If DTR/DSR handshaking is not used, jumper DTR\_232 to DSR\_232.
4. If nRST is used, it should be connected to an external switch to ground only, or to an open collector/drain driver. DO NOT CONNECT ANY VOLTAGE SOURCE TO THIS PIN.
5. SB300 Modem signals are inverted from the modem connector, as the two connectors are facing each other.

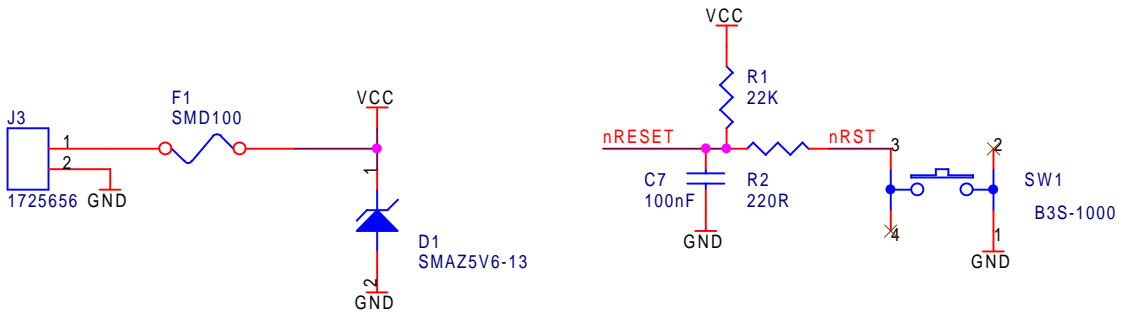

J-Tech Engineering Ltd. http://www.jtecheng.com		11080 Bond Boulevard Tel: 604 543 6272	Delta BC V4E 1M7 Fax: 604 543 6476
Title CDPD Modem Carrier			
Size A	Document Number CMCB21124	Rev 1.0	
Date: Friday, November 21, 2003		Sheet	1 of 1